



APOGEE OXYGEN METER | MO-200

Features

Heated Detector

The protective membrane can be heated to prevent water from condensing and blocking the diffusion path. The heater is typically used when sensors are deployed in soil or compost where relative humidity is close to 100 %.

Output Options

Available as an analog version with unamplified voltage output or digital version with SDI-12 communication protocol. Sensor also comes attached to a hand-held meter.

Internal Temperature Sensor

All oxygen sensors have an internal thermistor (type-K thermocouple is available upon request) that allows for temperature monitoring and correction of signal for temperature effects.

Simple Calibration

Output is proportional to oxygen concentration, enabling on-site calibration in open air conditions.

Typical Applications

Applications include: measurement of O_2 in laboratory experiments, monitoring gaseous O_2 in indoor environments for climate control, monitoring of O_2 levels in compost piles and mine tailings, monitoring redox potential in soils, and determination of respiration rates through measurement of O_2 consumption in sealed chambers or measurement of O_2 gradients in soil/porous media.

More gaseous O_2 in the laboratory and porous media

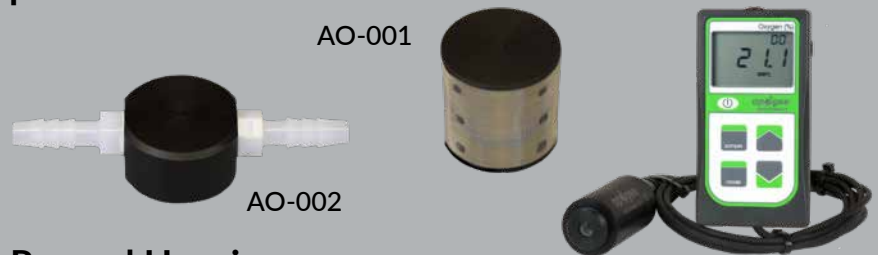

Rugged Housing

Housed in a polypropylene body and electronics are fully potted, ideal for long-term deployment in porous media, including acidic environments (mine tailings). Two head options are available: a diffusion head that creates a small air pocket for measurement in porous media and a flow-through head with two adapters for tubing that allows measurement of gas flowing in lines.



Dimensions

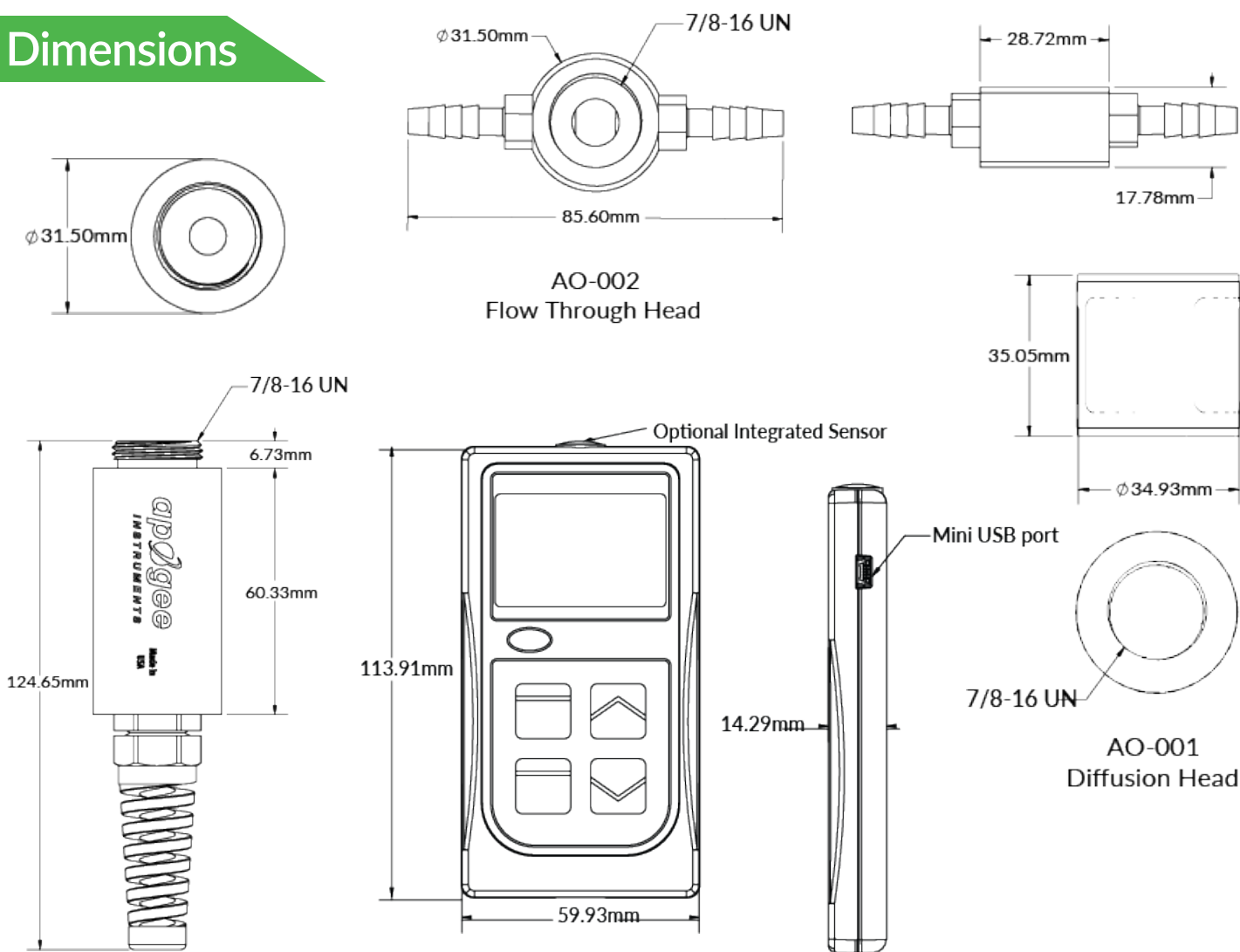

Product Specifications

	MO-200
Measurement Range	0 to 100 % O ₂
Measurement Repeatability	± 0.1 % at 20.9 % O ₂
Non-linearity	Less than 1 %
Oxygen Consumption Rate	2.2 μmol O ₂ per day at 20.95 % O ₂ and 23 C (galvanic cell sensors consume O ₂ in a chemical reaction with the electrolyte, which produces an electrical current)
Response Time	14 s (time required to read 90 % of saturated response)
Operating Environment	0 to 50 C; less than 90 % non-condensing relative humidity up to 30 C; less than 70 % non-condensing relative humidity from 30 to 50 C; 60 to 140 kPa
Meter Dimensions	126 mm length, 70 mm width, 24 mm height
Sensor Dimensions	32 mm diameter, 68 mm length
Diffusion Head (Accessory)	35 mm diameter, 35 mm length, 125 mesh screen
Flow Through Head (Accessory)	32 mm diameter, 91 mm length, 0.25 in barbed nylon connectors
Mass	210 g
Cable	2 m of two conductor, shielded, twisted-pair wire; additional cable available; TPR jacket (high water resistance, high UV stability, flexibility in cold conditions)
Influence from Various Gases	Sensors are unaffected by CO, CO ₂ , NO, NO ₂ , H ₂ S, H ₂ , and CH ₄ . There is a small effect (approximately 1 %) from NH ₃ , HCl, and C ₆ H ₆ (benzene). Sensors are sensitive to SO ₂ (signal responds to SO ₂ in a similar fashion to O ₂). Sensors can be damaged by O ₃ .
Warranty	4 years against defects in materials and workmanship