

SDI-12 Leaf Wetness Sensor

The TBSLWS leaf wetness sensor mimics the wetness state of a real leaf. The measurement value is proportional to the percentage of the sensor surface covered with water. The sensor is equipped with a SDI-12 interface for measurement and calibration.

In case of a standalone application, a built in temperature sensor can be queried for air temperature measurement. It is however no replacement for a dedicated air temperature sensor / radiation shield set up.



TBSLWS1 SDI-12 Leaf Wetness Sensor

Features

- Mimics the wetness state of a real leaf
- Measurement range: 0 %to 100%
- Measurement response: 1 sec
- SDI-12 Standard V1.3
- Plug and Play
- 6 - 16V supply voltage

- Less than 40 μ A idle current
- Operating Temperature Range:
- 40°C ... + 80°C

Target Applications

- SDI-12 Agri Yield Applications

SDI-12 Leaf Wetness Sensor

Contents

1	INTRODUCTION	3
2	MEASUREMENT	3
3	PRODUCT SPECIFICATION	4
4	CALIBRATION	4
5	INSTALLATION	5
6	SDI-12	5
7	APPLICATION EXAMPLES	6
8	MECHANICAL DIMENSIONS	7
9	CABLE CONNECTION	8
10	SUPPORTED SDI-12 COMMANDS	8
11	ORDERING INFORMATION	10
12	HISTORY	10

Tables

Table 1 – Cable Connection	8
Table 2 – Standard SDI-12 commands	9
Table 3 – Extended SDI-12 Commands	10
Table 4 – Ordering Information	10
Table 5 – History	10

Figures

Figure 1 – TBSLWS1 measurement output during rainfall and consecutive drying phase	3
Figure 2 – TBSLWS1 and other sensors with SDI-12 interface connected to TBS03 SDI-12 to USB converter; setup for controlling / testing sensors and for PC based data recording	6
Figure 3 – TBSLWS1 and other sensors with SDI-12 interface connected to Remote Telemetry Unit or Data Recorder	6

SDI-12 Leaf Wetness Sensor

1 Introduction

The graph below shows the output of the TBSLWS1 leaf wetness sensor. When the sensor is dry, the output value delivered upon a SDI-12 measurement command is 0% or very close to zero. When rain drops hit the surface of the sensor, the measurement response will be anywhere between 0% and 100%, depending on how much of the sensor area is covered with water drops. Typically the result will show some fluctuation during rainfall. Raindrops on the sensor surface merge to bigger drops until they reach a size where gravity exceeds surface adhesion and the drop flows from the sloped surface. Similarly, wind gusts can blow drops from the surface and change the state of wetness. Consequently there is some fluctuation in the amount of raindrops on the sensor surface during rainfall.

During the drying phase, the measurement curve is much smoother, as there is much less dynamics on the sensor surface compared to the phase of rainfall.

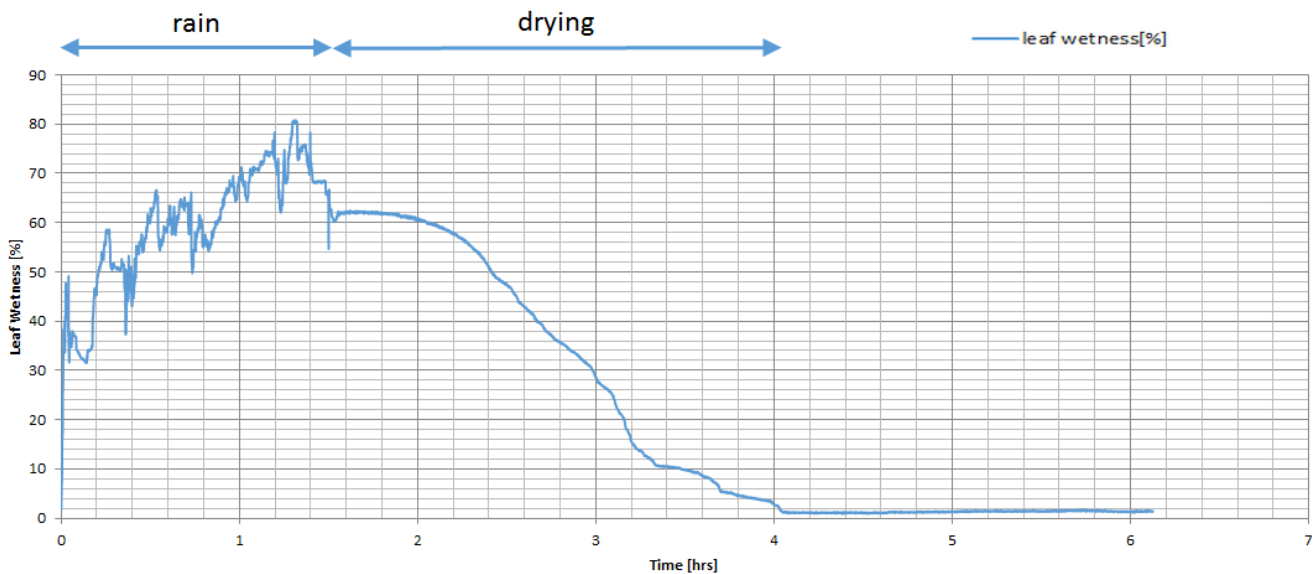

Figure 1 – TBSLWS1 measurement output during rainfall and consecutive drying phase

A measurement result of 100% is equivalent to the complete sensor surface submerged in water and a value of 0% is equivalent to a completely dry surface. The sensor comes factory calibrated. Upon requirement, the user can carry out an air/water calibration using extended SDI-12 commands.

2 Measurement

The TBSLWS1 outputs the measured leaf wetness in %:

Measurement commands:

aM!	aMC!	aC!	aCC!	Leaf wetness [%]
aM1!	aMC1!	aC1!	aCC1!	Leaf wetness [%] and board temperature [°C]
aM2!	aMC2!	aC2!	aCC2!	Board temperature [°C]

SDI-12 Leaf Wetness Sensor

The default measurement unit for board temperature is degree Celsius, however using an extended SDI-12 command, the result can be changed to Fahrenheit

Extended SDI-12 commands:

aXCA!	Air calibration	factory calibrated
aXCW!	Water calibration	factory calibrated

The leaf wetness sensor is factory calibrated and can be installed right out of the box. Refer to chapter 4 for details.

aXCT,ttt!	temperature calibration	factory calibrated
where s:	sign	
where tt.t:	ambient temperature measured with a reference thermometer	

The temperature calibration is carried out in production; in case of a re-calibration, allow the sensor half an hour to settle to room temperature

aXSTUu!	set temperature unit; u= C for °C; u=F for °F
aXGTU!	query temperature unit

Use the above command to configure the temperature unit; [°C] is the default setting

3 Product Specification

- Measurement range: 0 to 100%
- Measurement principle: capacitive measurement, PLL
- Measurement response: 1 sec
- SDI-12 Standard V1.3
- 6 - 16V supply voltage
- Operating Temperature Range: - 40°C ... + 80°C
- Current consumption: active 8mA (for 1 second); idle 30µA
- Standard cable length: 3m; any other length upon requirement

4 Calibration

The TBSLWS1 comes factory calibrated and does not need any user calibration.

The TBSLWS1 is air / water calibrated. For air calibration, the dry sensor is placed in a way that its surface is not touched by any object. Then issue the air calibration command. For water calibration, the complete sensor surface is submerged in water and then the calibration command is issued.

If a higher sensitivity is required, the water calibration can be carried out with the sensor surface not completely submerged in water, e.g. just half of the surface dipped into water when calibrating.

SDI-12 Leaf Wetness Sensor

5 Installation

The TBSLWS1 is compatible with any data logger or remote telemetry unit with SDI-12 interface. Refer to the data logger or RTU manual and to chapter 7 and 8 of this datasheet. Chapter 7 refers to the electrical installation; chapter 8 refers to the mechanical drawing.

The TBSLWS shall be mounted at an angle to mimic a leaf.

6 SDI-12

SDI-12 is a standard for interfacing data recorders with microprocessor-based sensors. SDI-12 stands for serial/digital interface at 1200 baud. It can connect multiple sensors with a single data recorder on one cable. It supports up to 60 meter cable between a sensor and a data logger.

The SDI-12 standard is prepared by

**SDI-12 Support Group
(Technical Committee)
165 East 500 South
River Heights, Utah
435-752-4200
435-752-1691 (FAX)
<http://www.sdi-12.org>**

The latest standard is version V1.3 which dates from July 18th, 2005. The standard is available on the website of the SDI-12 Support Group.

More information on SDI-12 is presented in chapter 3.

SDI-12 Leaf Wetness Sensor

7 Application Examples

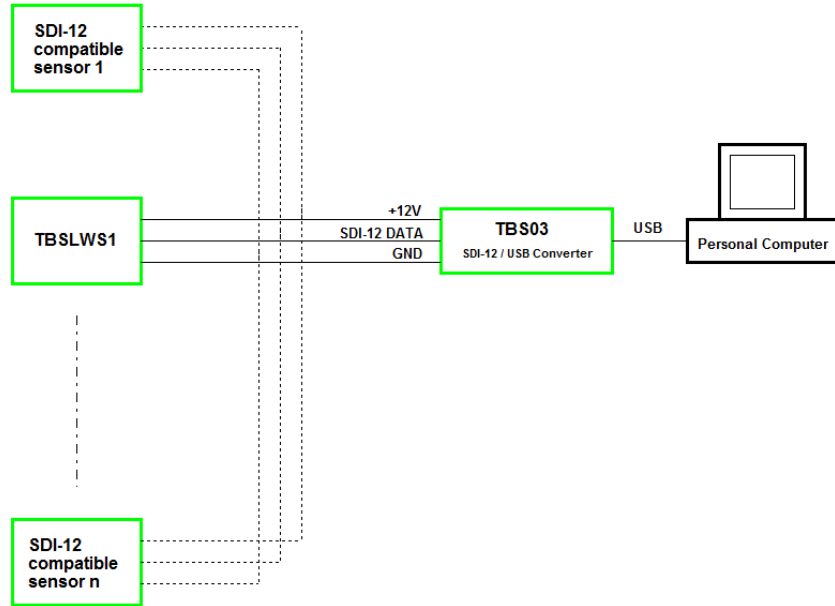

Figure 2 – TBSLWS1 and other sensors with SDI-12 interface connected to TBS03 SDI-12 to USB converter; setup for controlling / testing sensors and for PC based data recording

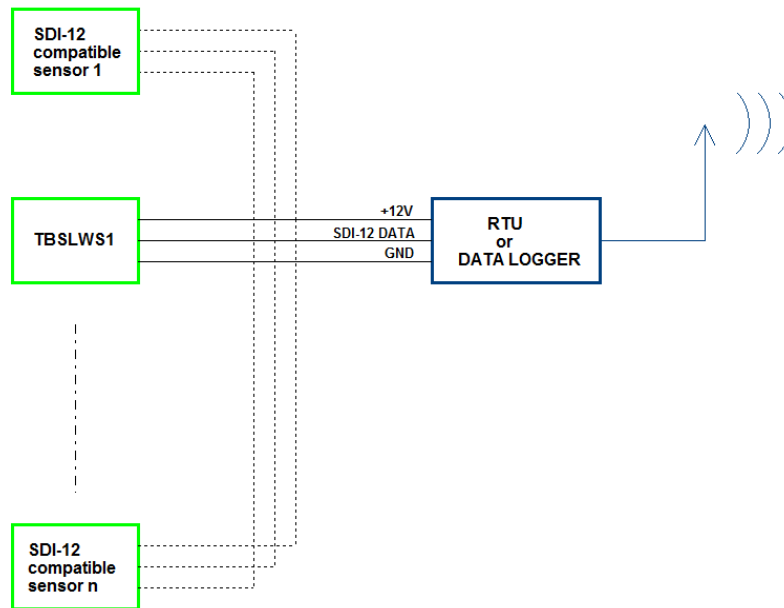
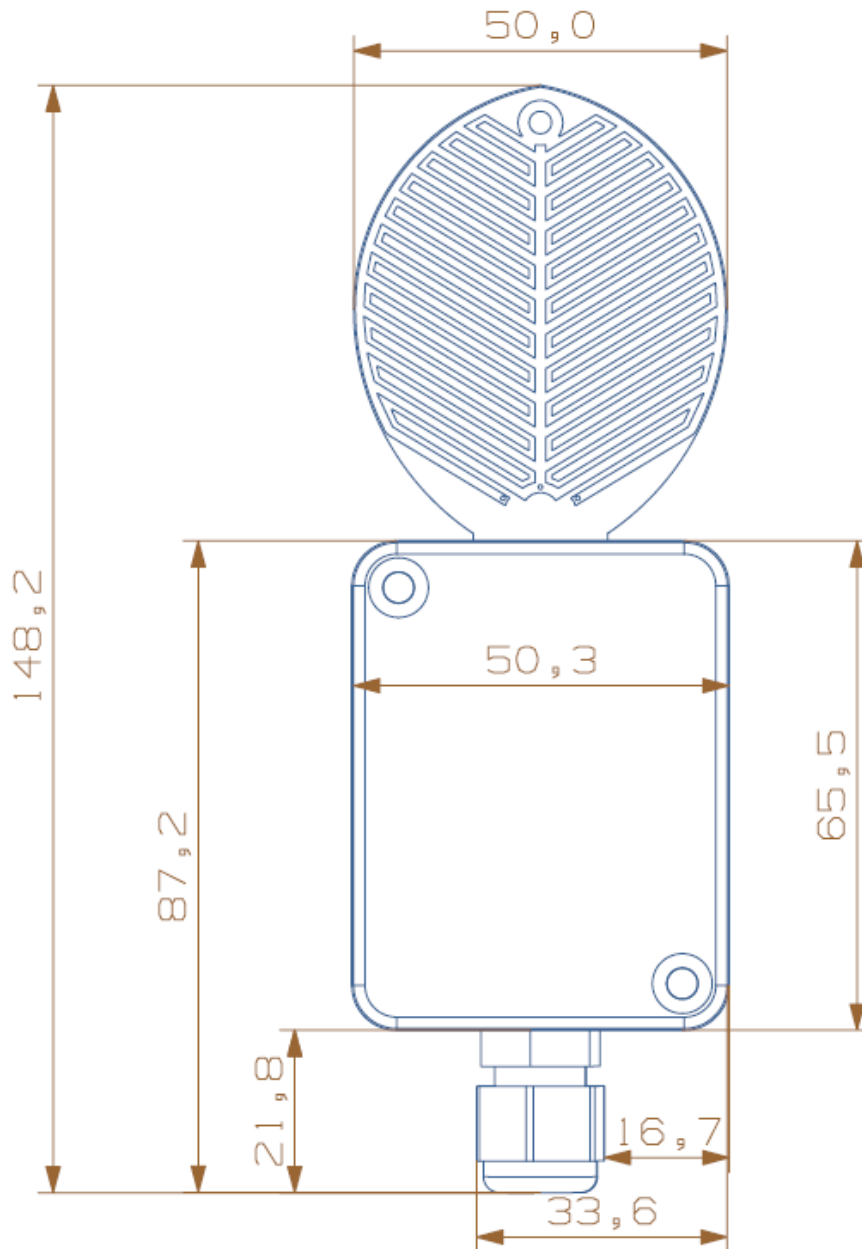

Figure 3 – TBSLWS1 and other sensors with SDI-12 interface connected to Remote Telemetry Unit or Data Recorder

SDI-12 Leaf Wetness Sensor

8 Mechanical Dimensions



SDI-12 Leaf Wetness Sensor

9 Cable Connection

Cable Colour	Signal Assignment
Blue	SDI-12 Power
Yellow	SDI-12 Data
Brown	GND
Black	Shield (GND)

Table 1 – Cable Connection

10 Supported SDI-12 Commands

Following standard SDI-12 commands are supported by the TBSLWS1:

Command	Description	Response
a!	Acknowledge Active	a<CR><LF>
al!	Send Identification	013TEKBOXVNTBSAB21.0000005xxxxx<CR><LF> With xxxxx representing the serial number
aAb!	Change Address	b<CR><LF> Changing the sensor address from a to b
?!	Address Query	a<CR><LF>
aM!	Start Measurement Measures leaf wetness [%]	att1<CR><LF> Delay (ttt = 001) in seconds and number of values (1)
aM1!	Additional Measurement Measures leaf wetness [%] and board temperature [°C/F]	att1<CR><LF> Delay (ttt = 001) in seconds and number of values (2)
aM2!	Additional Measurement Measures board temperature [°C/F]	att1<CR><LF> Delay (ttt = 001) in seconds and number of values (1)
aMC!	Start Measurement and request CRC Measures leaf wetness [%] and calculates CRC	att1<CR><LF> Delay (ttt = 001) in seconds and number of values (1)
aMC1!	Additional Measurement and request CRC Measures leaf wetness [%] and board temperature [°C/F] and calculates CRC	att1<CR><LF> Delay (ttt = 001) in seconds and number of values (1)
aMC2!	Additional Measurement and request CRC Measures board temperature [°C/F] and calculates CRC	att1<CR><LF> Delay (ttt = 001) in seconds and number of values (1)

SDI-12 Leaf Wetness Sensor

aC!	Start Concurrent Measurement Measures leaf wetness [%]	att1<CR><LF> Delay (ttt) in seconds and number of values (4)
aC1!	Start Concurrent Measurement Measures leaf wetness [%] and board temperature [°C/F]	att1<CR><LF> Delay (ttt) in seconds and number of values (4)
aC2!	Start Concurrent Measurement Measures board temperature [°C/F]	att1<CR><LF> Delay (ttt) in seconds and number of values (4)
aCC!	Start Concurrent Measurement and request CRC Measures leaf wetness [%] and calculates CRC	att1<CR><LF> Delay (ttt) in seconds and number of values (4)
aCC1!	Start Concurrent Measurement and request CRC Measures leaf wetness [%] and board temperature [°C/F] and calculates CRC	att1<CR><LF> Delay (ttt) in seconds and number of values (4)
aCC2!	Start Concurrent Measurement and request CRC Measures board temperature [°C/F] and calculates CRC	att1<CR><LF> Delay (ttt) in seconds and number of values (4)
aD0!	Get Measurement Result(s)	Upon issuing the aD0! Command, the TBSLWS1 will send the measurement results. The response format depends on the measurement command issued before.
aV!	Start Verification	a0000<CR><LF> Not supported
aRn! aRCn!	Continuous Measurement Continuous Measurement + CRC	a<CR><LF> Not supported

Table 2 – Standard SDI-12 commands

Following extended SDI-12 commands are supported by the TBSLWS1:

Command	Description	Response
aXCA!	Air calibration Place the dry sensor in air and issue the air calibration command. Do not touch the surface, while calibrating.	aX_ok<CR><LF>
aXCW!	Water calibration Submerge the sensor surface into a glass filled with water and issue the water calibration command.	aX_ok<CR><LF>
aXCT, stt.tt	Temperature calibration s: sign tt.tt: ambient temperature measured with a reference thermometer	aX_ok<CR><LF>
aXSTUu!	Set temperature unit u = F for [°C], u = f for [°F]	aX_ok<CR><LF>
aXGTU!	Query temperature unit	au<CR><LF>

SDI-12 Leaf Wetness Sensor

Table 3 – Extended SDI-12 Commands

11 Ordering Information

Part Number	Description
TBSLWS1	TBSLWS1, Leaf wetness sensor with 3m cable

Please mention in your order, if you require a different cable length

Table 4 – Ordering Information

12 History

Version	Date	Author	Changes
V1.0	24.06.2014	Mayerhofer	Creation of the document
V1.1	17.10.2014	Mayerhofer	Correction of temperature calibration command: sign added
V1.2	18.02.2015	Mayerhofer	Corrections
V1.3	22.04.2020	Mayerhofer	Update page 1 Picture Update Mechanical Dimensions
V1.4	22.06.2020	Mayerhofer	Correction 9 Cable Connection

Table 5 – History